

## Selfie



- Designed to enable easy bending into a curve.
- Ready to be bent into L-shaped, S-shaped, U-shaped and other shaped curves.
- Special bender enables bending by hand at the installation site.

## Exceptionally easy installation.

- The rail is vertically symmetrical and not direction-sensitive, resulting in easier, more efficient installation.
- The horizontally symmetrical I-shaped design makes the bend easy to undo.

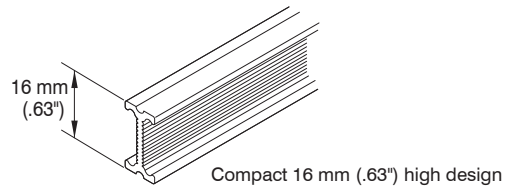

## Curving flexibility.

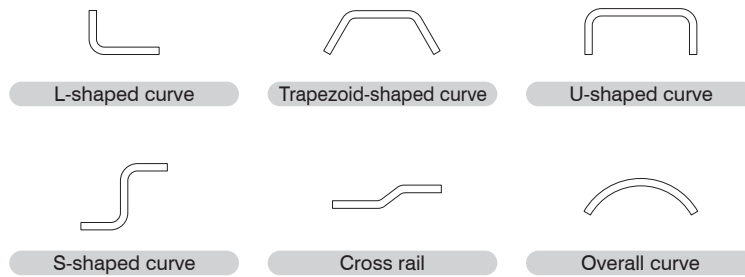

## Materials and Finishes

Parts	Material	Finish
Rail	Aluminum alloy extrusion material	Alumite, Alumite umber, Alumite white
Roller	Plate	Hard polyethylene
	Wheel	Acetal resin
	Oval ring	Stainless steel

Parts	Material	Finish
End Cap	Plate	Hard polyethylene
	Stop plate	Steel
	Oval ring	Stainless steel
Bracket	Body	Steel
	Snap board	Steel

## Bracket Installation Interval and Allowable Curtain Load

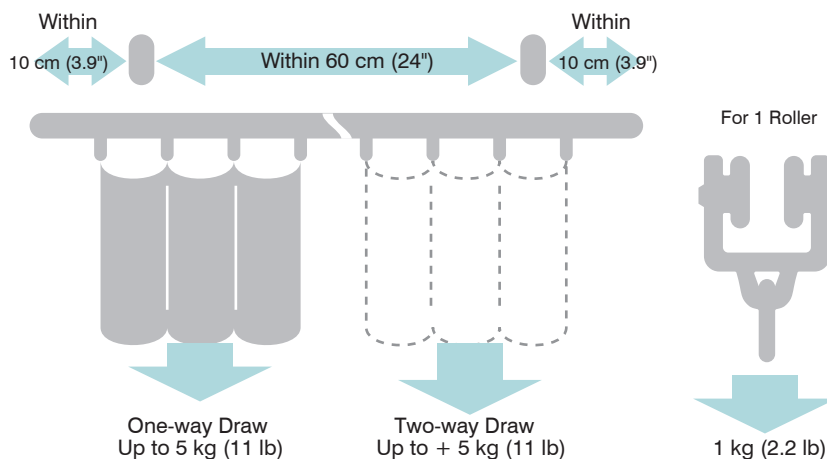

## Installation Dimensions

### Ceiling Attachment

Easy Snap Ceiling Single Bracket

Bracket width = 18 mm (.71")

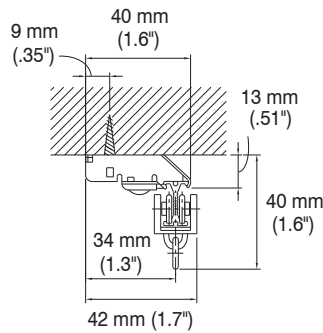

### Wall Attachment

Single Bracket

Bracket width = 18 mm (.71")

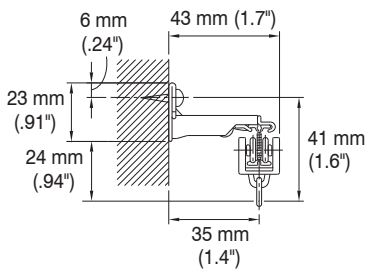

Double Bracket

Bracket width = 18 mm (.71")

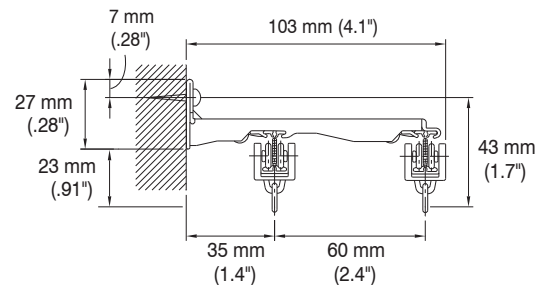

## Selfie Rails

Warm white



Size	Product Code
	Warm white
1.82 m (72")	02330030
2.00 m (79")	02330031
3.00 m (118")	02330033
3.64 m (143")	02330034
4.00 m (157")	02330035

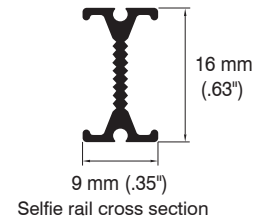

## Basic Installation Curving Method

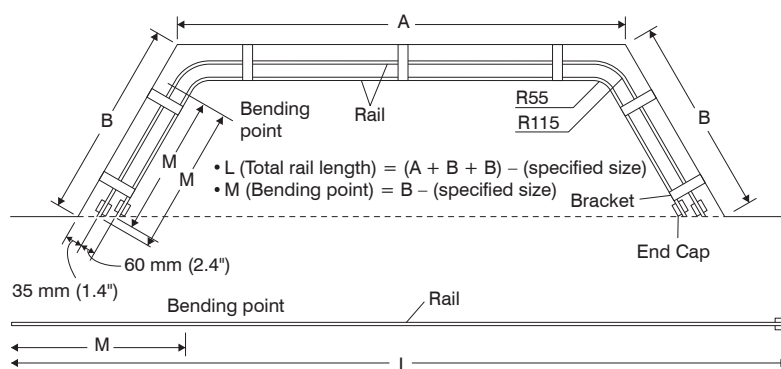

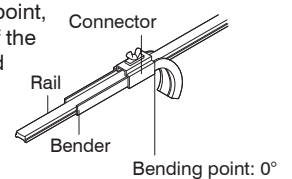

1. At the rail bending point, align the 0° point of the bender with the end of the clamp and secure.



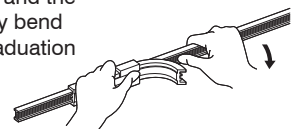

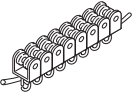

2. Hold the bender and the rail and gradually bend the rail to the graduation mark of the desired angle.

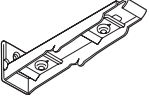

Selfie Parts

	Product Name		Product Code
Rollers	Roller (8 pieces per strip) 	Natural	60610199NA02
	MG Carrier 	Natural	60610199NA07
Brackets	Single Bracket 	Silver	02330111
	Double Bracket 	Silver	02330112

	Product Name		Product Code
Brackets	Ceiling Single Bracket 	Silver	02330114
	End Cap 	Natural	02330110
Other Parts	Joint Pin 		02330027
	Curve Bender 55R 		02330028